



INOGENI U-BRIDGE USB-C

User guide

Version 1.0

June 23, 2026

VERSION HISTORY

Version	Date	Description
0.1	June 4, 2026	Preliminary version.
1.0	June 23, 2026	Official release.

CONTENTS

Version history.....	1
Typical applications	3
Setups with the SINGLE version.....	3
Setup with the DUO version	5
Device interfaces	6
LEDs behavior	8
Operating modes	9
USB-C extension video 4K60 and USB 2.0.....	9
USB 3.0	9
Specifications	10
REST API.....	12
Telnet.....	13
API Commands	14
INOGENI Maestro application.....	18
Web interface access.....	19
STATUS tab.....	20
SETTINGS tab	20
USB.....	20
Display	21
CEC display control	21
SYSTEM tab	22
Security	22
Web interface configuration.....	22
Network	23
Update.....	23
RESOURCES tab	24
Mechanical specification	26
PC HOST hub – SINGLE	26
PC HOST hub – DUO	27
DEVICE hub - SINGLE.....	28
DEVICE hub – DUO.....	29
Mounting bracket.....	30
60W power supply bracket	30
100W USB-C power supply bracket.....	31

DIP switches.....	32
Troubleshooting section.....	32
Support.....	33
Certifications.....	33

TYPICAL APPLICATIONS

Here are typical connection diagrams used for the U-BRIDGE USB-C and U-BRIDGE USB-C DUO device in a video-conferencing setup.

SETUPS WITH THE SINGLE VERSION

The device can connect natively to a video-conferencing system depending on the connections available, such as USB & HDMI or using USB-C DisplayPort Alternate Mode.

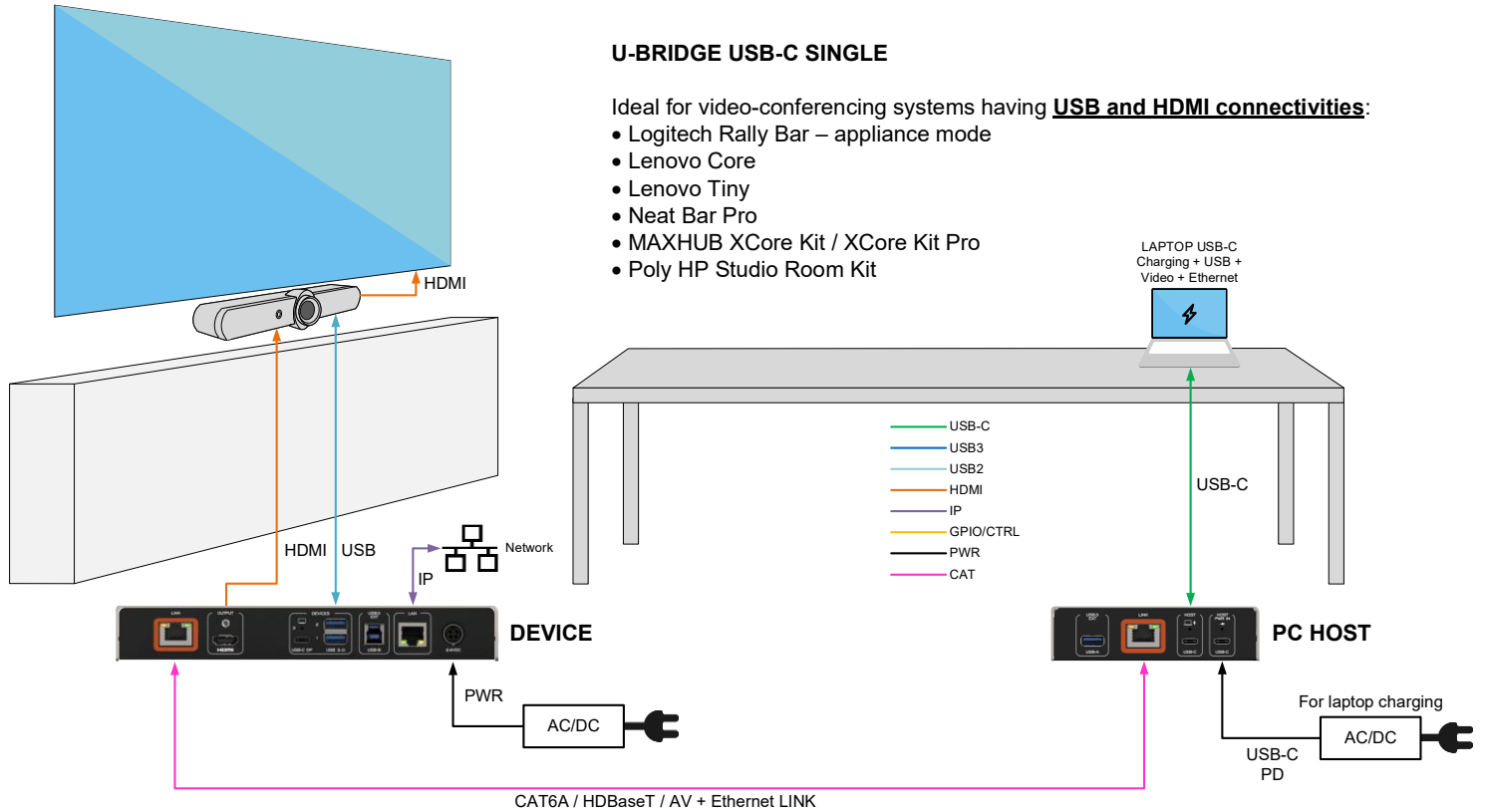

If your video-conferencing system supports dual-displays, you can interface with the device in the following fashion.

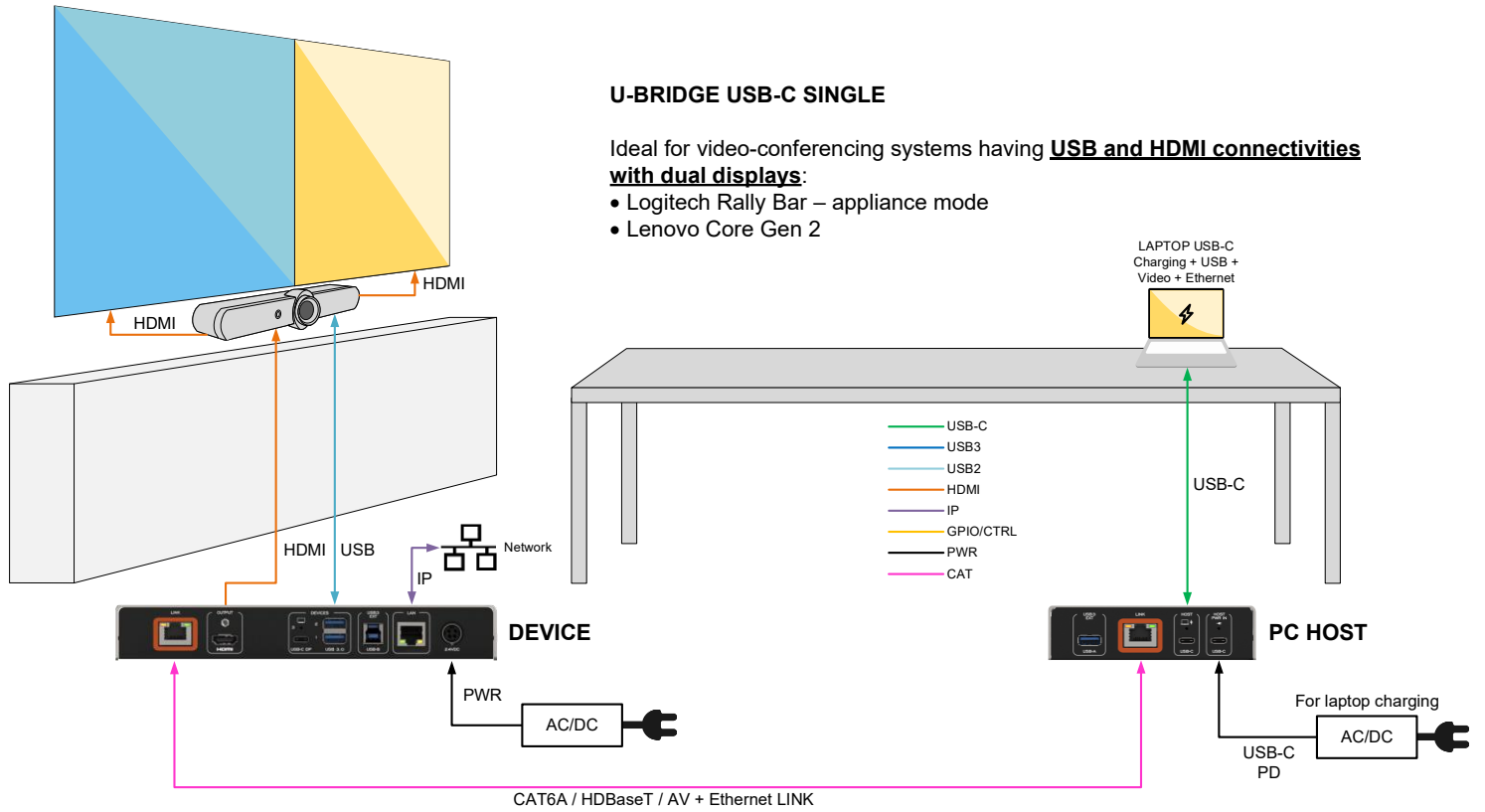

If you do not target to use a video-conferencing system and operate exclusively in BYOM, you can easily interface your AV peripherals directly with the device.

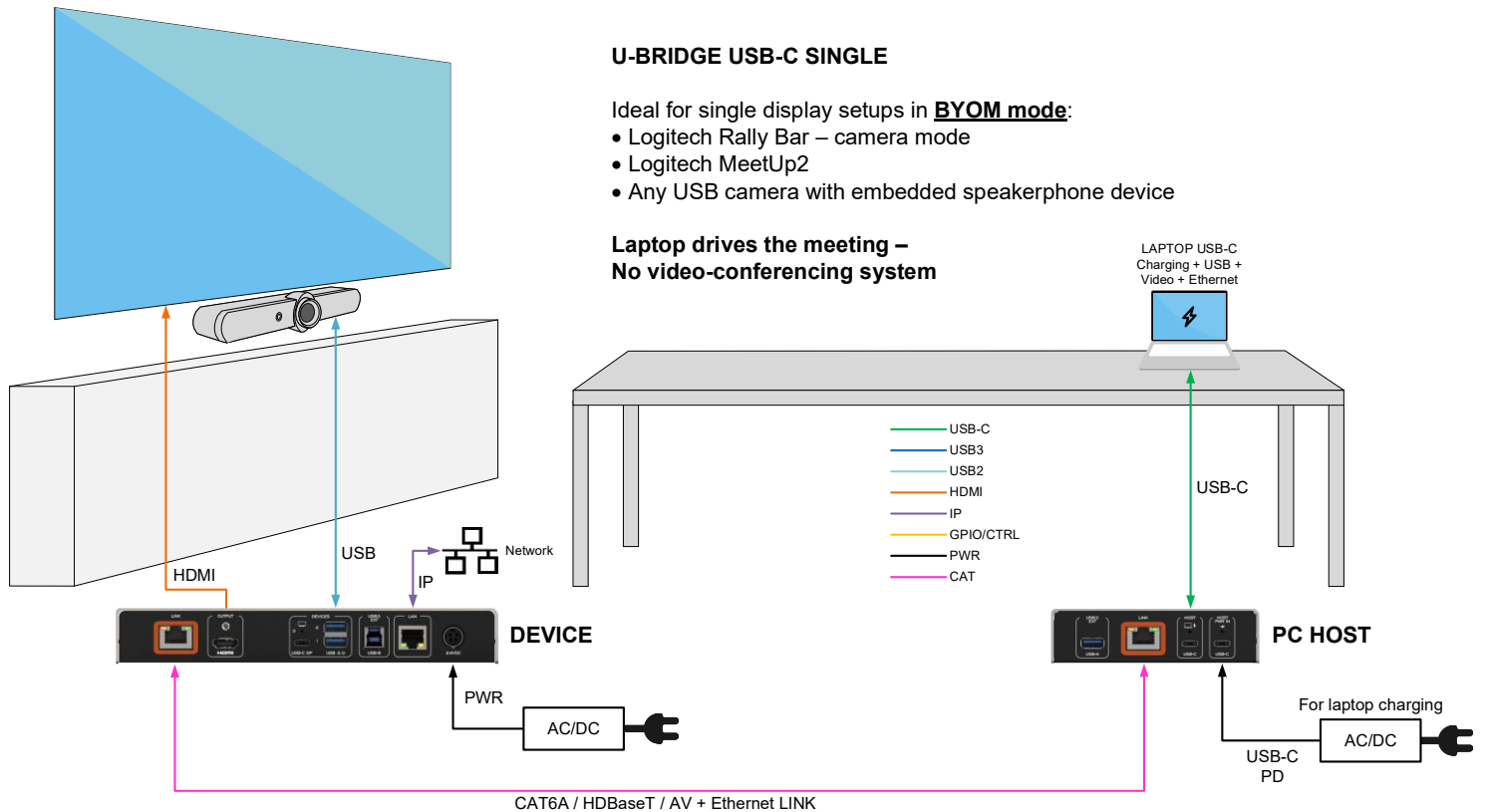

SETUP WITH THE DUO VERSION

Using the DUO version, you can connect natively to a dual display setup.

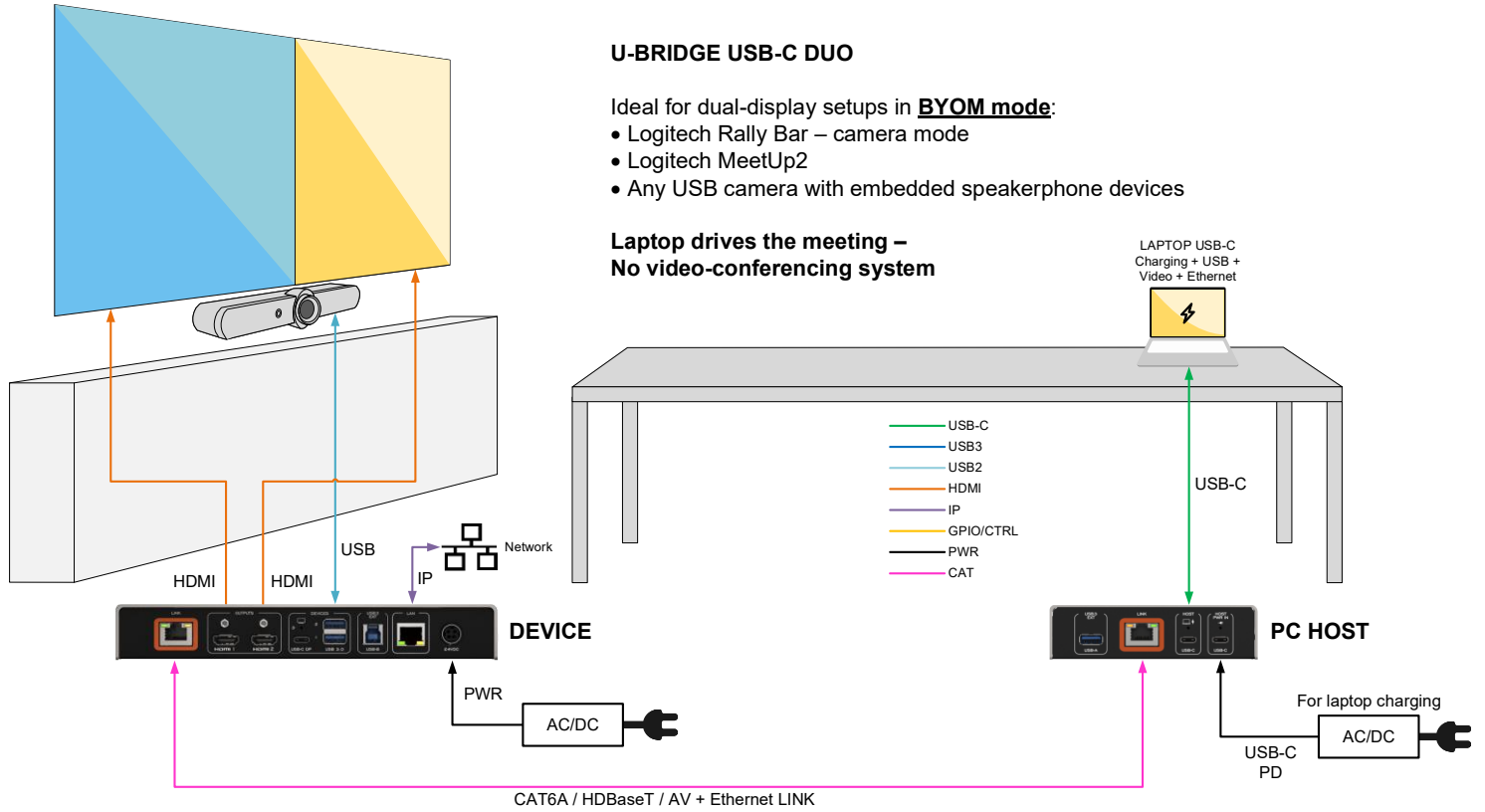

DEVICE INTERFACES

Here are the devices interfaces.

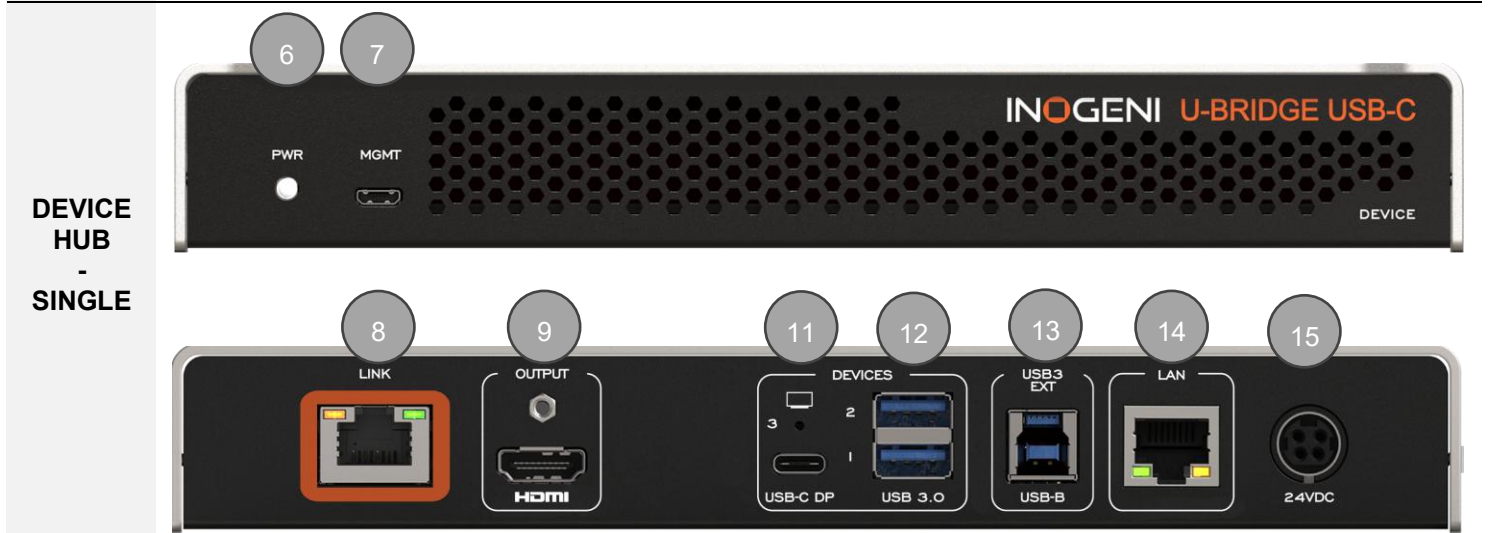
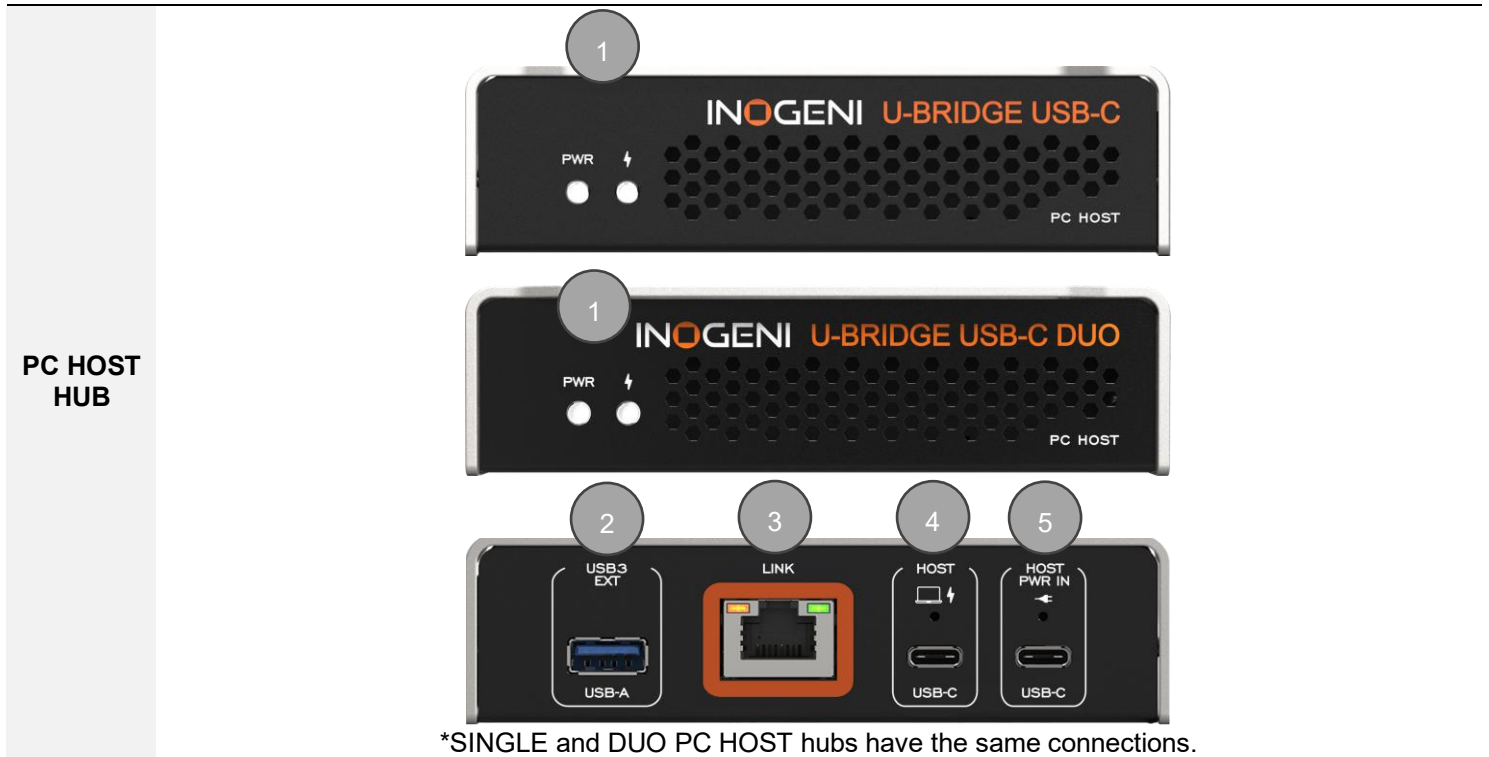

Items		
PC HOST HUB	1	PWR and charging status leds
	2	USB-A / USB 3.0 extender connection
	3	HDBaseT link
	4	USB-C laptop connection
	5	USB-C power supply connection
DEVICE HUB	6	PWR status led
	7	Micro-USB for management – Must use this port to operate the Maestro application.
	8	HDBaseT link
	9	HDMI output 1
	10	HDMI output 2 – Supported in DUO version only
	11	USB-C device connection. This port supports DisplayPort Alternate Mode and can be connected to devices which accept a DisplayPort Alternate Mode signal such as USB-C ingest of a video-conferencing computer.
	12	USB-A devices connection
	13	USB-B / USB3.0 extender connection
	14	LAN interface
	15	24VDC power input

LEDS BEHAVIOR

Here are the LEDs behavior:

PWR	
OFF	Device not powered.
SOLID	Device powered.
Charging 	
OFF	Laptop is not charging.
SOLID	Laptop is charging.
Link Orange LED	
OFF	No HDBaseT connection detected.
SOLID	HDBaseT connection detected.
Link Green LED	
OFF	No video signal over HDBaseT connection.
SOLID	Video signal with HDCP content.
BLINK	Video signal with no HDCP content.

OPERATING MODES

Here are the operating modes supported by the device. They will be explained here.

USB-C EXTENSION VIDEO 4K60 AND USB 2.0

This is the default mode. All USB-C data from PC HOST hub are routed to the DEVICE hub using HDBaseT link.

USB 3.0

To enable USB 3.0 connectivity, the user needs to connect a USB 3.0 extension (like the [INOGENI U-BRIDGE 3](#)) between both hubs on the USB3-EXT connectors. Video will go through the HDBaseT link and USB signal will go through the USB3-EXT interface.

U-BRIDGE USB-C application with U-BRIDGE 3

USB-C extension of USB and DisplayPort Alternate Mode up to 70 m (230 ft.) over CAT6A U/FTP PoE

INOGENI

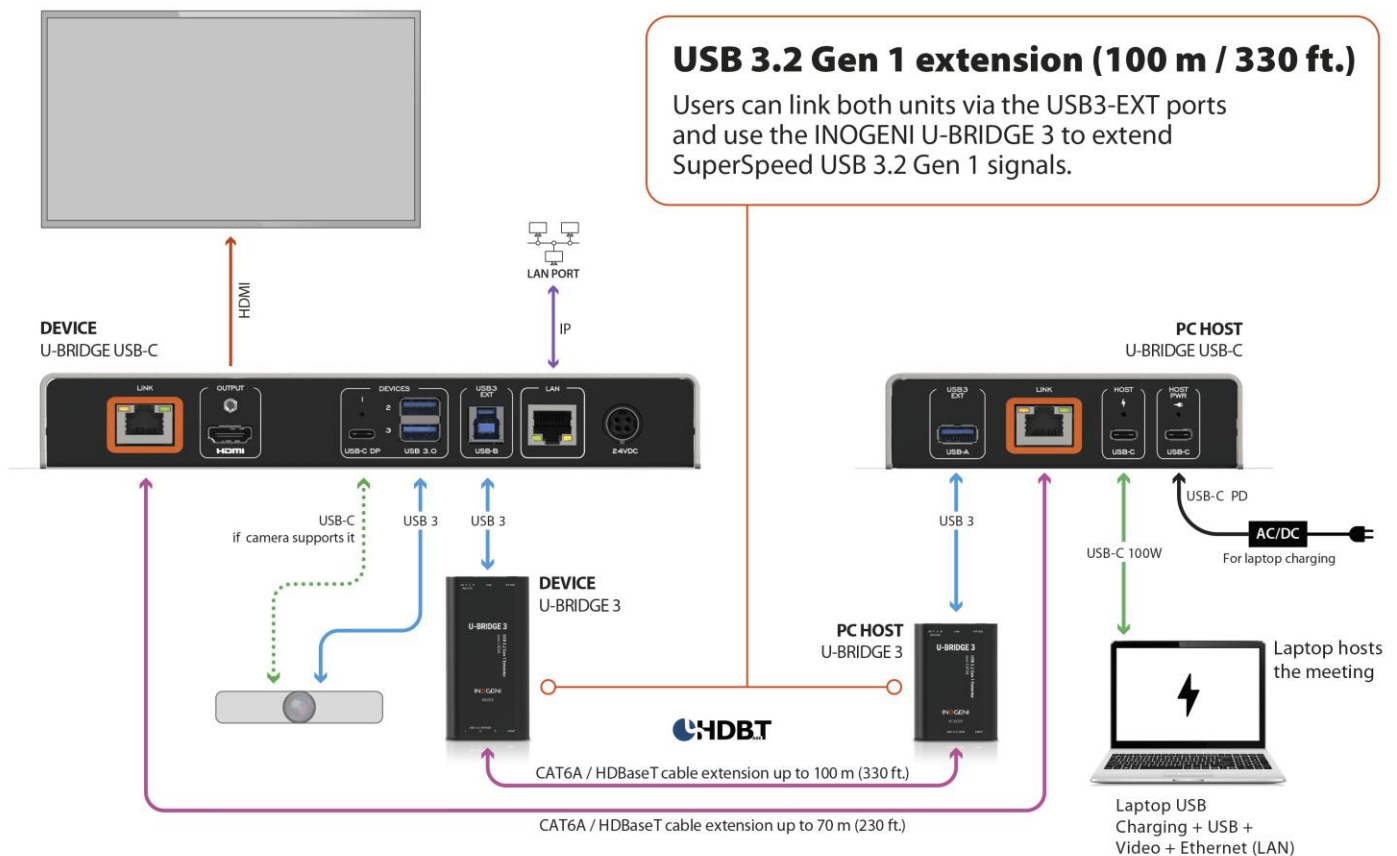

SPECIFICATIONS

Here is the marketing specification to be announced to customers.

Main feature	
Description	The U-BRIDGE USB-C extender enables extension of USB and DisplayPort Alternate Mode up to 70m (230ft) over CAT6A U/FTP
Link	
Technology	HDBaseT 3.0
Range	Direct connect up to 70m (230ft) over CAT6A U/FTP (HDMI 4K30) Direct connect up to 40m (131ft) over CAT6A U/FTP (HDMI 4K60)
Medium	CAT6A U/FTP NOTE: We do not recommend using a crimp tool for attaching terminations. Instead, we highly recommend utilizing toolless terminations to ensure the preservation of signal integrity.
USB	
Speeds	USB 2.0: up to 480 Mbps when USB devices are extended * USB 3.2 Gen 1 if devices are extended with the use of our U-BRIDGE 3 extension
Transfers support	Bulk, isochronous, interrupt and control types Built-in hardware acceleration for isochronous and bulk transfers
Video - HDMI	
HDCP compliance	Compliant with HDCP2.3, HDCP2.2 and HDCP1.4
HDMI compliance	Compliant with HDMI2.0b and HDMI1.4
Sampling frequency	600MHz
Chroma subsampling	YUV/RGB 4:4:4, 4:2:2
CEC	Ability to send CEC commands to connected HDMI display sink
PC HOST extender	
USB host connector	1 x USB Type-C receptacle with mounting screw hole for connection to the laptop. <ul style="list-style-type: none"> - USB2.0 - USB 3.2 Gen 1 (with the use of our U-BRIDGE 3 extension) - Video up to 3840x2160p60 / 4096x2160p60 - Charging through provided USB-C power supply - Network connectivity <div style="text-align: center;">  <p>No network connectivity available using macOS system. This will be supported in a next hardware revision.</p> </div>
USB power connector	1 x USB Type-C receptacle with mounting screw hole for USB-C power supply <ul style="list-style-type: none"> - Power source input - USB2.0 connection reserved for management
Link connector	1 x RJ45
USB3-EXT connector	1 x USB-A connector for connection to our U-BRIDGE 3 for USB3.2 Gen 1 support.
LED	1 x power LED 1 x charging status LED
Dimensions (W x L x H)	12.0 cm x 14 cm x 3.3 cm 4.72 " x 5.51 " x 1.18 "
Weight	470 g (1.04lb)
Mounting	Brackets provided
Enclosure material	Aluminum / metal case
Power	PC HOST is powered by the DEVICE module, except for charging the laptop.
DEVICE extender	
USB connectors	2 x USB-A (USB3.2 Gen 1) receptacle 1 x USB-C (USB3.2 Gen 1) receptacle with mounting screw hole
Video outputs	Single display : <ul style="list-style-type: none"> • 1 x USB-C DisplayPort Alternate Mode – Source • 1 x HDMI 2.0 receptacle with cable locking option Up to 3840x2160p60 / 4096x2160p60

NOTE: If you connect a DisplayPort Alternate Mode device on the USB-C port, the HDMI output will not be used since USB-C is taken in priority.

DUO – Dual displays :

- 1 x USB-C DisplayPort Alternate Mode – Source
- 2 x HDMI 2.0 receptacles with cable locking option
Up to 3840x2160p60 / 4096x2160p60

NOTE: If 2x displays are connected at the same time, each video output can go up to 3840x2160p30. This is an HDBaseT limitation.

NOTE: If you connect a DisplayPort Alternate Mode device on the USB-C port, the HDMI1 output will not be used since USB-C is taken in priority. HDMI2 output will work as intended.

Link connector	1 x RJ45
USB3-EXT connector	1 x USB-B connector for connection to our U-BRIDGE 3 for USB3.2 Gen 1 support.
LED	1 x power LED
Available current	USB-A : 900mA by port USB-C : 3A
Dimensions (W x L x H)	22.3 cm x 14 cm x 3.3 cm 8.78 " x 5.51 " x 1.18 "
Weight	820 g (1.81lb)
Mounting	Brackets provided
Enclosure material	Aluminum / metal case
IP interface	10/100Mbps Supports DHCP or static addressing Used for control / management and USB-C network connectivity over the PC HOST module.

Physical details	
Package dimensions	35.5 cm x 29 cm x 12.6 cm 14.0" x 11.4" x 4.96"
Power supplies	100-240V AC Input, 24V 2.5A DC output 100-240V AC Input, USB-C P TO 20V 5A DC output
Package weight	3610 g (9.96 lbs)
Package contents	1x PC HOST extender module 1x DEVICE extender module 1x USB Type-C to Type-C cable 1x micro-USB to USB-A cable 1x installation guide 2x mounting brackets for the power supply 2x mounting brackets for the USB-C power supply 2x mounting brackets for the PCHOST module 2x mounting brackets for the DEVICE module 16x black wooden screws 1x power supply 100-240V AC Input, 24V 2.5A DC output 1x USB-C power supply – 100-240V AC input, up to 20V 5A DC output International power adapter with country-specific cord (North America, EU, UK, Australia/NZ, or Japan)
Operating temperature	0°C to 50°C 32°F to 122°F
Storage temperature	-20°C to 70°C -4°F to 158°F
Operating humidity	20% to 80% relative humidity, non-condensing
Storage humidity	10% to 90% relative humidity, non-condensing

Information	
Single display – UPC code	051497480417
Dual display – UPC code	051497480431
Origin	Canada
Warranty	5 years

Certifications	
Certifications device	FCC, CE, UKCA, RoHS, SoV, RCM, NOM
Certifications - Power supply 60W	FCC, CE, UKCA, CB, UL, TUV, EMC, IEC62368
Certification – Power supply 100W	FCC, CE, UKCA
TAA-Compliant	Yes

You can enable a bearer authentication in the HTTP header (Authorization: Bearer <token>) through our configuration page to increase security on the API.

There will be a return code to each call with the following commands:

```
200 OK - Request successful
400 Bad Request - Invalid request
401 Unauthorized - Authentication required
404 Not Found - Resource not found
500 Internal Server Error - Server error
```

The return body will usually be JSON formatted with a "message" field containing a JSON string explaining the cause of the error or "success" in case of success. Note that we are using self-signed certificates.

It is also possible to embed arguments to an API call inside the URL to ease configuration with some control systems with the following topology:

```
GET https://<IP>/api/v1/<COMMAND>?<ARG1>=value&<ARG2>=value
```

where <COMMAND>, <ARG1> and <ARG2> are command and associated arguments.

For example, using the **ethHostEn** command, you can issue the following request:

```
GET https://<IP>/api/v1/ethHostEn?enable=1
```

This request will enable the network connectivity on the USB-C host connection.

The following commands allow to perform password management and bearer token management. By default, no authentication is required to perform action using the REST API. Authentication can be enabled through the embedded webpage or the REST API itself.

Command URL / Description	Body arguments	Return body
HTTP POST https://<IP>/api/v1/changePassword Change the password to <newPassword>.	<pre>{ "oldPassword": "<oldPassword>", "newPassword": "<newPassword>" }</pre>	<pre>{ "message": <String> }</pre>
HTTP GET https://<IP>/api/v1/accessToken Return the bearer token.		<pre>{ "token": <String> "message": <String> }</pre>
HTTP POST https://<IP>/api/v1/accessToken Generate random access token and activate bearer token authentication for REST API.		<pre>{ "token": <String> "message": <String> }</pre>
HTTP DELETE https://<IP>/api/v1/accessToken Delete and deactivate bearer token.		<pre>{ "message": <String> }</pre>
HTTP GET https://<IP>/api/v1/accessTokenEn?enable=<number> Activate (1) or Deactivate (0) access token for REST APIs		<pre>{ "message": <String> }</pre>

The bearer token is generated using a random process. The format of the bearer token only supports the following:

- Alphanumeric (A to Z) upper and lowercase characters.
- Numbers 0-9.

See the “API Commands” section for all the commands available.

TELNET

You can use any telnet application to communicate with the device using TCP. Make sure to use the right IP address and **port 23**.

Use the serial communication protocol to configure the device.

The `quit` command can be used to ask server for disconnection.

See the “API Commands” section for all the commands available.

API COMMANDS

Here is the list of the telnet and RESTAPI commands available for the device. The two interfaces share the same API.

TX When command have all body arguments, it will apply the configuration to the device.

RX When command does not have any body arguments or only first argument is provided, it will return information from the device.

API command (TELNET - RESTAPI)	Description	REQ	TELNET payload	TELNET return	RESTAPI payload	RESTAPI return
AUTOHDMICECPWR - autoHdmiCecPwr	Get/Set the automatic CEC power control of the connected display. When enabled, the device will turn on/off the display depending on the actual state of the video source routed to the display. <enable> options: 0 => OFF 1 => ON	TX	<enable>	ACK<CR><LF>	enable=<enable>	{ "message": <String> }
		RX		ENABLE=<enable><CR><LF> ACK<CR><LF>		{ "enable": <enable>, "message": <String> }
BLVERSION - blVersion	Return bootloader version.	RX		MAJOR=<Integer><CR><LF> MINOR=<Integer><CR><LF> ACK<CR><LF>		{ "blmajor": <Integer>, "blminor": <Integer> }
CECTOGGLEMUTE - cecToggleMute	Toggle mute control. <sink> options: 1 => HDMI OUT 1 2 => HDMI OUT 2*	TX	<sink>	ACK<CR><LF>	sink=<sink>	{ "message": <String> }
CECVOLDOWN - cecVolDown	Decrease display volume. <sink> options: 1 => HDMI OUT 1 2 => HDMI OUT 2*	TX	<sink>	ACK<CR><LF>	sink=<sink>	{ "message": <String> }
CECVOLUP - cecVolUp	Increase display volume. <sink> options: 1 => HDMI OUT 1 2 => HDMI OUT 2*	TX	<sink>	ACK<CR><LF>	sink=<sink>	{ "message": <String> }
CECPOWER - cecPower	Control the display power state. <sink> options: 1 => HDMI OUT 1 2 => HDMI OUT 2* <pwr> option: 0 => Power OFF 1 => Power ON	TX	<sink> <pwr>	ACK<CR><LF>	sink=<sink> pwr=<pwr>	{ "message": <String> }
EDID - edid	Set specific EDID modes to be reported to video source. <src> options: 0 => USB-C IN 1 1 => USB-C IN 2* <edid> options: 0 => Passthrough 1 => User EDID 2 => 3840x2160p60 3 => 3840x2160p50 4 => 3840x2160p30 5 => 3840x2160p25	TX	<src> <edid>	ACK<CR><LF>	src=<src> edid=<edid>	{ "message": <String> }
		RX	<src>	EDID=<edid><CR><LF> ACK<CR><LF>	src=<src>	{ "edid": <edid>, "message": <String> }

	6 => 1920x1080p60 7 => 1920x1080p50 8 => 1280x720p60 9 => 1280x720p50					
EDIDHDMIOUT - edidHdmiOut	Get/Set the EDID from the sink and report it to the associated source. This will put the EDID mode of the associated source to "User EDID". <sink> options: 0 => USB-C OUT 1 => HDMI OUT 1 2 => HDMI OUT 2* <src> options: 0 => USB-C IN 1 1 => USB-C IN 2* <edidHdmiOut> => formatted 256 bytes array	TX	<sink> <src>	ACK<CR><LF>	sink=<sink> src=<src>	{ "message": <String> }
		RX	<sink>	EDIDUSR=<edidUsr><CR><LF> ACK<CR><LF>	sink=<sink>	{ "edidHdmiOut": <edidHdmiOut>, "message": <String> }
EDIDUSER - edidUsr	Set specific EDID modes to be reported to video source. <src> options: 0 => USB-C IN 1 1 => USB-C IN 2* <edidUsr> => formatted 256 bytes array	TX	<src> <256 bytes array>	ACK<CR><LF>	edidUsr=<256 bytes array>	{ "message": <String> }
		RX	<src>	EDIDUSR=<edidUsr><CR><LF> ACK<CR><LF>	src=<src>	{ "edidUsr": <edidUsr>, "message": <String> }
ETHHOSTEN - ethHostEn	Get/Set ethernet connection control setting reported to the USB-C host. <enable> options: 0 => OFF 1 => ON	TX	<enable>	ACK<CR><LF>	enable=<enable>	{ "message": <String> }
		RX		ENABLE=<enable><CR><LF> ACK<CR><LF>		{ "enable": <enable>, "message": <String> }
FORMAT - format	Get video format. <port> options: 0 => USB-C IN 1 / USB-C OUT 1 => USB-C IN 2* / HDMI OUT 1 2 => NA / HDMI OUT 2* <isInput> options: 0 => Output 1 => Input	RX	<port> <isInput>	FORMAT=<format><CR><LF> ACK<CR><LF>	port=<port> isInput=<isinput>	{ "format": <format> "message": <String> }
HELP - help	Return commands list with description.	RX		List of all the supported commands.		List of all the supported commands.
HOSTNAME - hostName	Get/Set the hostname of the device. This command will change the device name when probed over the network and the name of the USB HID interface. <hostname> option: String defined hostname to be shown on the network and USB HID interface. This string must not have space characters.	TX	<hostname>	ACK<CR><LF>	hostname=<hostname>	{ "message": <String> }
		RX		HOSTNAME=<src><CR><LF> ACK<CR><LF>		{ "hostname": <host>, "message": <String> }
HTTPEN - httpEn	Get/Set HTTP control setting. <enable> options: 0 => OFF 1 => ON	TX	<enable>	ACK<CR><LF>	enable=<enable>	{ "message": <String> }
		RX		ENABLE=<enable><CR><LF> ACK<CR><LF>		{ "enable": <enable>, }

					"message": <String> }
HWVERSION - hwVersion	Return hardware version.	RX	MAJOR=<Integer><CR><LF> MINOR=<Integer><CR><LF> ACK<CR><LF>		{ "hwmajor": <Integer>, "hwminor": <Integer> }
LINKSTATUS - linkStatus	Get HDBaseT link status. <status> indicates the link status. 0 => No link 1 => Active link If no active link is detected, next values should be ignored. <len> indicates the estimated length in meters. <q> indicates the quality factor. HDBTMAXERR, HDBTMSE and HDBTMSEWINDOW fields will report the associated measurement to a specific channel <chx> of the HDBaseT connection. The HDBTMAXERR will report the current errors measured over the link. For an appropriate measurement of the signal quality, we recommend getting the HDBTMSE and HDBTMSEWINDOW values to calculate the signal to noise ratio associated to a specific channel using the following formula: MSE (dB) $= 10 \cdot \log_{10} \left(\frac{HDBTMSE+1}{2^{14} \cdot HDBTMSEWINDOW[i]} \right)$ If MSE (dB) > -9 dB, the current link is bad. <ret> indicates the retransmission rate over the link. 0 => No retransmission	RX	HDBTLINK=<status><CR><LF> HDBTCABLEL=<len><CR><LF> HDBTCABLEQ=<q><CR><LF> HDBTMAXERR=<cha>, <chb> <chc>, <chd><CR><LF> HDBTMSE=<cha>, <chb> <chc>, <chd><CR><LF> HDBTMSEWINDOW=<cha>, <chb> <chc>, <chd><CR><LF> HDBTRETRANRATE=<ret> ACK<CR><LF>		{ "Link": { "HdbtLink": <status>, "HdbtCableLength": <len>, "HdbtCableQuality": <q>, "HdbtMaxError": ["cha", "chb", "chc", "chd"] , "HdbtMse": ["cha", "chb", "chc", "chd"] , "HdbtMseWindow": ["cha", "chb", "chc", "chd"] , "HdbtRetransmissionRate": <ret> }
MDNSEN - mdnsEn	Get/Set mDNS control setting. <enable> options: 0 => OFF 1 => ON	TX <enable>	ACK<CR><LF>	enable=<enable>	{ "message": <String> }
NETWORK - network	Configure network settings. <mode> options: static => addressing is static dhcp => use DHCP addressing If mode is static, IP and netmask are required while gateway is optional. <ip> option: String defined IP address. Example: 192.168.0.20	TX <mode> <ip> <netmask> <gateway>	ACK<CR><LF>	mode=<mode> ip=<ip> netmask=<netmask> gateway=<gateway>	{ "message": <String> }
		RX	MODE=<mode><CR><LF> IP=<ip><CR><LF> NETMASK=<netmask><CR><LF> GATEWAY=<gateway><CR><LF> ACK<CR><LF>		{ "mode": <static,dhcp>, "ip": <ip>, "netmask": <netmask>, "gateway": <gateway>, }

	<p><netmask> option: String defined netmask address. Example: 255.255.0.0</p> <p><gateway> option: String defined gateway address. Example: 192.168.0.1</p>				<pre>"message": <String> }</pre>	
QUIT - quit	TELNET disconnection.	TX		ACK<CR><LF>		<pre>{ "message": <String> }</pre>
REBOOT - reboot	Reboot the device.	TX		ACK<CR><LF>		<pre>{ "message": <String> }</pre>
RSTR - rstr	Restore default settings (including password and REST API token).	TX		ACK<CR><LF>		<pre>{ "message": <String> }</pre>
STATUS - status	Return laptop, modules and configuration information.	RX			List of all the status of the device.	List of all the status of the device.
TELNETEN - telnetEn	Get/Set TELNET control setting.	TX	<enable>	ACK<CR><LF>		<pre>{ "message": <String> }</pre>
	<enable> options: 0 => OFF 1 => ON	RX		ENABLE=<enable><CR><LF> ACK<CR><LF>		<pre>{ "enable": <enable>, "message": <String> }</pre>
USB3EN - usb3En	Get/Set USB 3.0 control setting.	TX	<enable>	ACK<CR><LF>		<pre>{ "message": <String> }</pre>
	<enable> options: 0 => OFF 1 => ON	RX		ENABLE=<enable><CR><LF> ACK<CR><LF>		<pre>{ "enable": <enable>, "message": <String> }</pre>
USBDEVEN - usbDevEn	Get/Set the power on USB devices ports according to specific hosts.	TX	<devices> <enable>	ACK<CR><LF>		<pre>{ "message": <String> }</pre>
	<devices> options: 0 => DEV 1 (USB-A BOTTOM) 1 => DEV 2 (USB-A TOP) 2 => DEV 3USB (USB-C)	RX	<device>	DEVICES=<devices><CR><LF> ACK<CR><LF>		<pre>{ "devices": <devices>, "message": <String> }</pre>
	<enable> options: 0 => OFF 1 => ON				devices=<devices>	
VERSION - version	Return firmware version.	RX		MAJOR=<Integer><CR><LF> MINOR=<Integer><CR><LF> ACK<CR><LF>		<pre>{ "major": <Integer>, "minor": <Integer>, "patch": <Integer> }</pre>

* Applies only to the U-BRIDGE USB-C DUO since this product will manage a second video stream.

You can use our [INOGENI Maestro](#) application to monitor firmware information and upgrade your unit.

NOTE: To allow Maestro to detect the unit over USB, connect a **micro-USB to USB-A cable** between the **DEVICE** module and your computer. Alternatively, you can connect the kit to your network and follow the procedure in the “web interface access” section.



Maestro Device controller

STATUS | SETTINGS | SYSTEM | RESOURCES | REBOOT DEVICE

GENERAL INFO

DEVICE NAME: UBridgeUSBC

FIRMWARE VERSION	1.0.0	USB-C DP INPUT	Not detected	HDBT LINK	Active
MAC ADDRESS	38:76:05:30:00:B7	HDMI OUTPUT	No video	HDBT CABLE LENGTH	~2 m (7 ft)
IP ADDRESS	192.168.0.116	USB-C DP OUTPUT	No video	HDBT SIGNAL INTEGRITY	OK
SERIAL NUMBER	UUE6260095			HDBT PAIR INTEGRITY	A B C D

GENERAL

Firmware version	1.0.0
Hardware Revision	1.2
MAC address	38:76:05:30:00:B7
IP Mode	DHCP
IP address	192.168.0.116
Subnet Mask	255.255.255.0
Gateway	192.168.0.1

DEVICE CONFIGURATION

Ethernet to USB-C bridge	Enabled
--------------------------	---------

PC HOST

USB-C	Detected
-------	----------

VIDEO OUTPUTS

USB-C	
Monitor	Not Detected

WEB INTERFACE ACCESS

A web interface is available for the device. This one is accessible through your network.



Since the device supports the mDNS networking protocol, you can access the web interface of the device using the link-local networking URL below the device next to the MAC address under the DEVICE hub. This URL will end with the **.local** suffix like shown in this example:

38:76:05:00:90:03
ubridge-usbc-009003.local

You can access the device using any browser and enter the URL with the **.local** suffix or the IP address of the unit if you have this information. You will be prompted with a login dialog. At first connection, the device will ask you to configure a new password.

UBRIDGE USB-C SINGLE

First connection

Please choose a password to protect your UBRIDGE USB-C SINGLE device.

Enter password:

Re-enter password:

Submit

UBRIDGE USB-C SINGLE

Login

Password:

Submit

When you enter the web interface, buttons at the top up the page will allow you to navigate to different tabs.

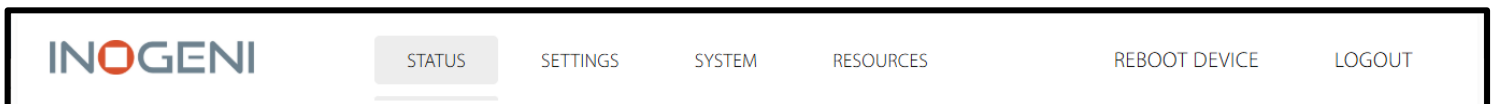

- Buttons to reboot the unit and the logout action.

You will also get access to the general information of the device. This information is always available when you navigate through the tabs.

GENERAL INFO



DEVICE NAME
UBRIDGE-USBC-3000b7

FIRMWARE VERSION	1.0.0	USB-C DP INPUT	Not detected	HDBT LINK	Active
MAC ADDRESS	38:76:05:30:00:B7	HDMI OUTPUT	No video	HDBT CABLE LENGTH	~2 m (7 ft)
IP ADDRESS	192.168.0.116	USB-C DP OUTPUT	No video	HDBT SIGNAL INTEGRITY	OK
SERIAL NUMBER	UUE6260095			HDBT PAIR INTEGRITY	A B C D

- General section with firmware version, MAC address, IP address and serial number of the unit.
- Status of video inputs and outputs

- HDBaseT / Link information like estimated distance and signal integrity over the CAT cable pairs.

STATUS TAB

This section contains all the firmware information, video sources detections/resolutions along with the actual configuration of the unit.

<p>GENERAL</p> <table border="1"> <tr><td>Firmware version</td><td>1.0.0</td></tr> <tr><td>Hardware Revision</td><td>1.2</td></tr> <tr><td>MAC address</td><td>38:76:05:30:00:B7</td></tr> <tr><td>IP Mode</td><td>DHCP</td></tr> <tr><td>IP address</td><td>192.168.0.116</td></tr> <tr><td>Subnet Mask</td><td>255.255.255.0</td></tr> <tr><td>Gateway</td><td>192.168.0.1</td></tr> </table>	Firmware version	1.0.0	Hardware Revision	1.2	MAC address	38:76:05:30:00:B7	IP Mode	DHCP	IP address	192.168.0.116	Subnet Mask	255.255.255.0	Gateway	192.168.0.1	<p>DEVICE CONFIGURATION</p> <table border="1"> <tr><td>Ethernet to USB-C bridge</td><td>Enabled</td></tr> </table>	Ethernet to USB-C bridge	Enabled
Firmware version	1.0.0																
Hardware Revision	1.2																
MAC address	38:76:05:30:00:B7																
IP Mode	DHCP																
IP address	192.168.0.116																
Subnet Mask	255.255.255.0																
Gateway	192.168.0.1																
Ethernet to USB-C bridge	Enabled																
<p>PC HOST</p> <table border="1"> <tr><td>USB-C</td><td>Detected</td></tr> </table> <p>DISPLAY</p> <table border="1"> <tr><td>EDID mode</td><td>Passthrough</td></tr> </table>	USB-C	Detected	EDID mode	Passthrough	<p>VIDEO OUTPUTS</p> <p>USB-C</p> <table border="1"> <tr><td>Monitor</td><td>Not Detected</td></tr> <tr><td>Resolution</td><td>No Video</td></tr> </table> <p>HDMI</p> <table border="1"> <tr><td>Monitor</td><td>Not Detected</td></tr> <tr><td>Resolution</td><td>No Video</td></tr> </table>	Monitor	Not Detected	Resolution	No Video	Monitor	Not Detected	Resolution	No Video				
USB-C	Detected																
EDID mode	Passthrough																
Monitor	Not Detected																
Resolution	No Video																
Monitor	Not Detected																
Resolution	No Video																

SETTINGS TAB

USB

USB

Enable Ethernet to USB-C bridge

Enable USB #1

Enable USB #2

Enable USB-C

- USB configuration
 - o User can configure the Ethernet to USB-C bridge reported to the laptop.
 - o User can also configure the VBUS state of the USB device ports.

DISPLAY

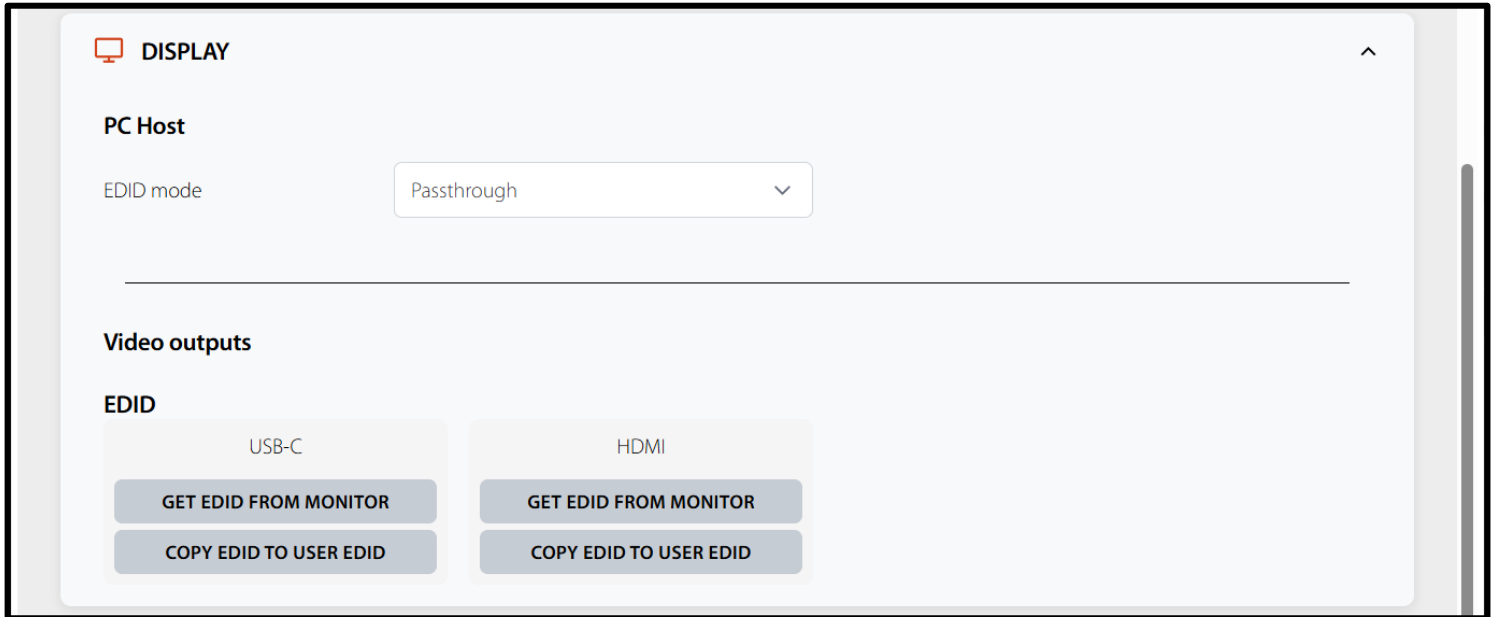

- PC Host
 - o EDID mode
 - Can report EDID information based on actual display, using preset EDIDs or using a user EDID that can be uploaded to the device.
- Video outputs
 - o User can get the EDID from a sink and use it as a User EDID.

CEC DISPLAY CONTROL

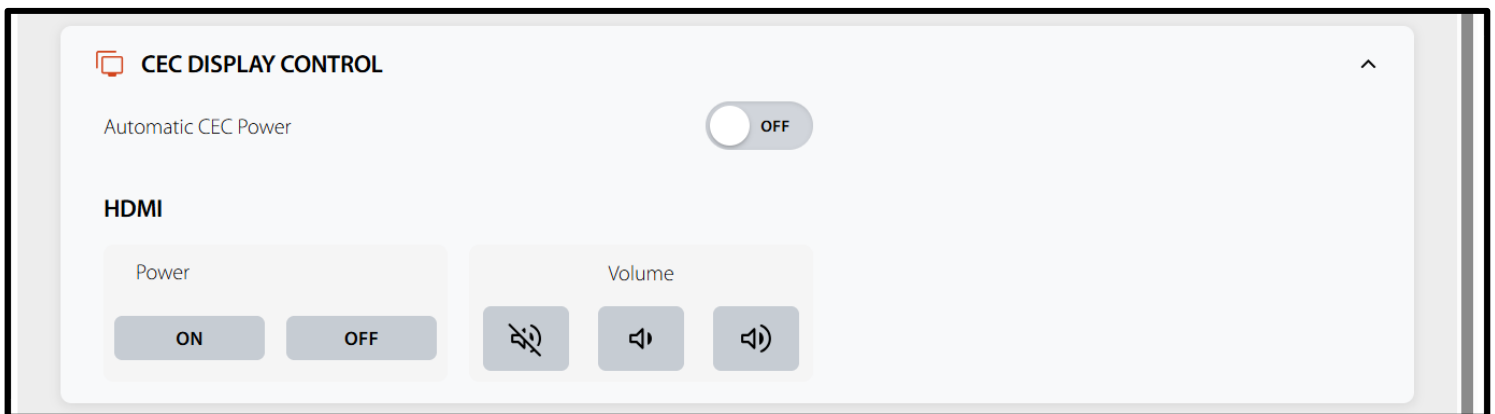

- Automatic CEC power
 - o Device can automatically send power ON/OFF commands to display when the laptop is detected or not.
- Power
 - o Can turn ON/OFF connected display.
- Volume
 - o Can send volume UP/DOWN commands.
 - o Can send toggle mute command.

SECURITY

SECURITY

Login info

Change the login info

Old password: *

New password: *

Confirm new password: *

* mandatory fields

SAVE

Telnet Connection

- Login info
 - o Ability to change the current password of the device.
- Telnet connection
 - o Allows the device to be connected to a telnet client.

WEB INTERFACE CONFIGURATION

WEB INTERFACE CONFIGURATION

HTTP Server

Authenticate with token

API access token

GET ACCESS TOKEN GENERATE ACCESS TOKEN

DELETE ACCESS TOKEN

Upload TLS certificate

Choose certificate

Choose private key

- Ability to turn on or off the HTTP server.
- Allow the authentication token.
- API access token can be accessed, generated or deleted using those buttons.
- You can also configure a certificate along with its private key.

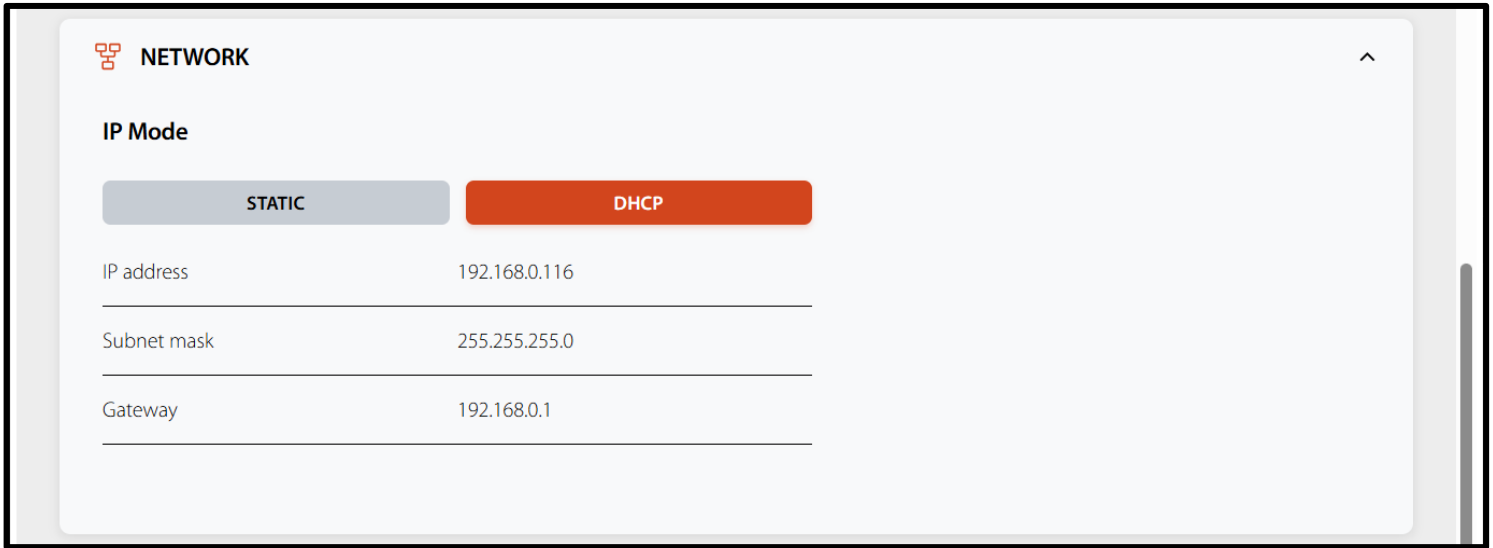

- IP mode
 - o Device can be configured using DHCP or static IP address.
 - o If static IP addressing is selected, you can set IP address, subnet mask and gateway.

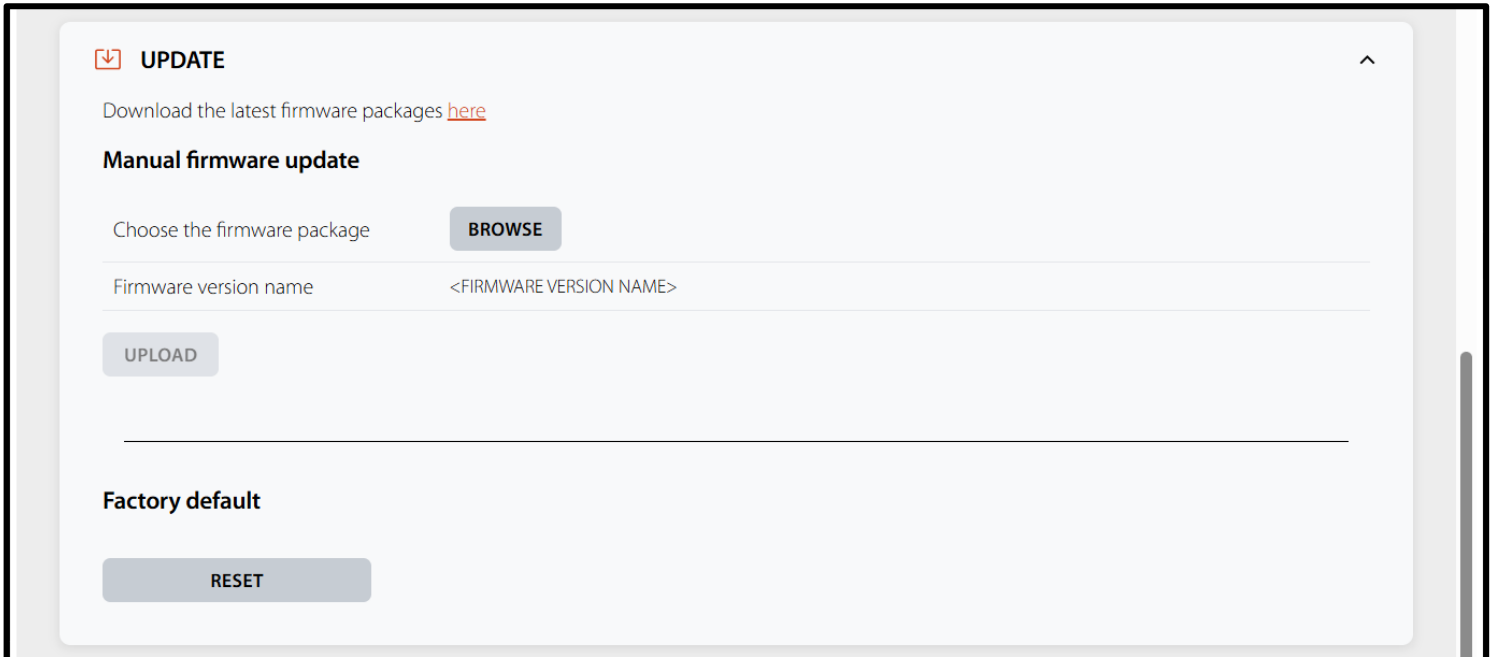

- You can force a specific firmware package (ZIP file) after clicking on the “Browse” button. Click on “Upload” button to proceed to the update.
- If you need to do a factory reset of the product, you can click on the “Reset” button.







 **GUIDES** ^

 UBRIDGE USB-C - User Guide 
 UBRIDGE USB-C - Brochure 
 UBRIDGE USB-C - Sales Sheet 
 UBRIDGE USB-C - Quick Start Guide 















In this section, you will have access to the latest documentation.

- User guide
- Datasheet
- Brochure
- Device certifications
- Power supplies certification

 **DEVICE CERTIFICATIONS** ^

 FCC-CE-RoHS-IEC62368 - Declaration of Conformity 
 SoV - Declaration of Volatility 
 TAA - Declaration of TAA Compliance 

 **POWER SUPPLY CERTIFICATIONS - 60W** ^

 CB - TUV - Test Certificate 
 CE - Declaration of Conformity 
 FCC - Verification of Compliance 
 KC - Certificate 
 RCM - Certificate 
 TUV - Certificate 
 UL - Certificate 

 **POWER SUPPLY CERTIFICATIONS - USB-C - 100W** ^

- [!\[\]\(57e6eaa370c11c0a8b197170cf41ea3b_img.jpg\) EMC - Attestation of Conformity !\[\]\(dbb5925b453b6e9e7a1719382db80907_img.jpg\)](#)
- [!\[\]\(04c2c12129b7b86c4fdf9dd599794af8_img.jpg\) KCC - Certificate !\[\]\(36bb223857a09d55e764be5cd85bd32e_img.jpg\)](#)
- [!\[\]\(e547f5f938aec4f3824ce0f9f2875501_img.jpg\) RCM - Certificate !\[\]\(d02b5b693bb89ec29e346bfb9279e371_img.jpg\)](#)
- [!\[\]\(febed13798b953e6336efab7f87002dc_img.jpg\) RCM - Letter of Authorisation !\[\]\(bd4c122dbc7c9912c582eb9e5b2b7380_img.jpg\)](#)
- [!\[\]\(3373e66925bf25a3171d941fb1e2176f_img.jpg\) UKCA - EMC - Attestation of Conformity !\[\]\(c485bcaa2986f1b8d18aa15a6c6d33a9_img.jpg\)](#)
- [!\[\]\(29408ea95c27eba092d5b3753322773e_img.jpg\) UKCA - LVD - Attestation of Conformity !\[\]\(d19261ed36f2e3b9a7df24c7a56113b5_img.jpg\)](#)
- [!\[\]\(a9341b3c7a1421d51d638ce92ccfcba4_img.jpg\) UL - CB - Certificate !\[\]\(dc7f208b4fad449ccbbe1156ec8e5050_img.jpg\)](#)
- [!\[\]\(937fb1785a62a0698b3de23710075412_img.jpg\) TUV - CE - Certificate !\[\]\(7e9aff633a8e0bb24303152e65135c7e_img.jpg\)](#)

MECHANICAL SPECIFICATION

You can find the mechanical specification of the device. All dimensions are in **mm [in]**.

PC HOST HUB – SINGLE

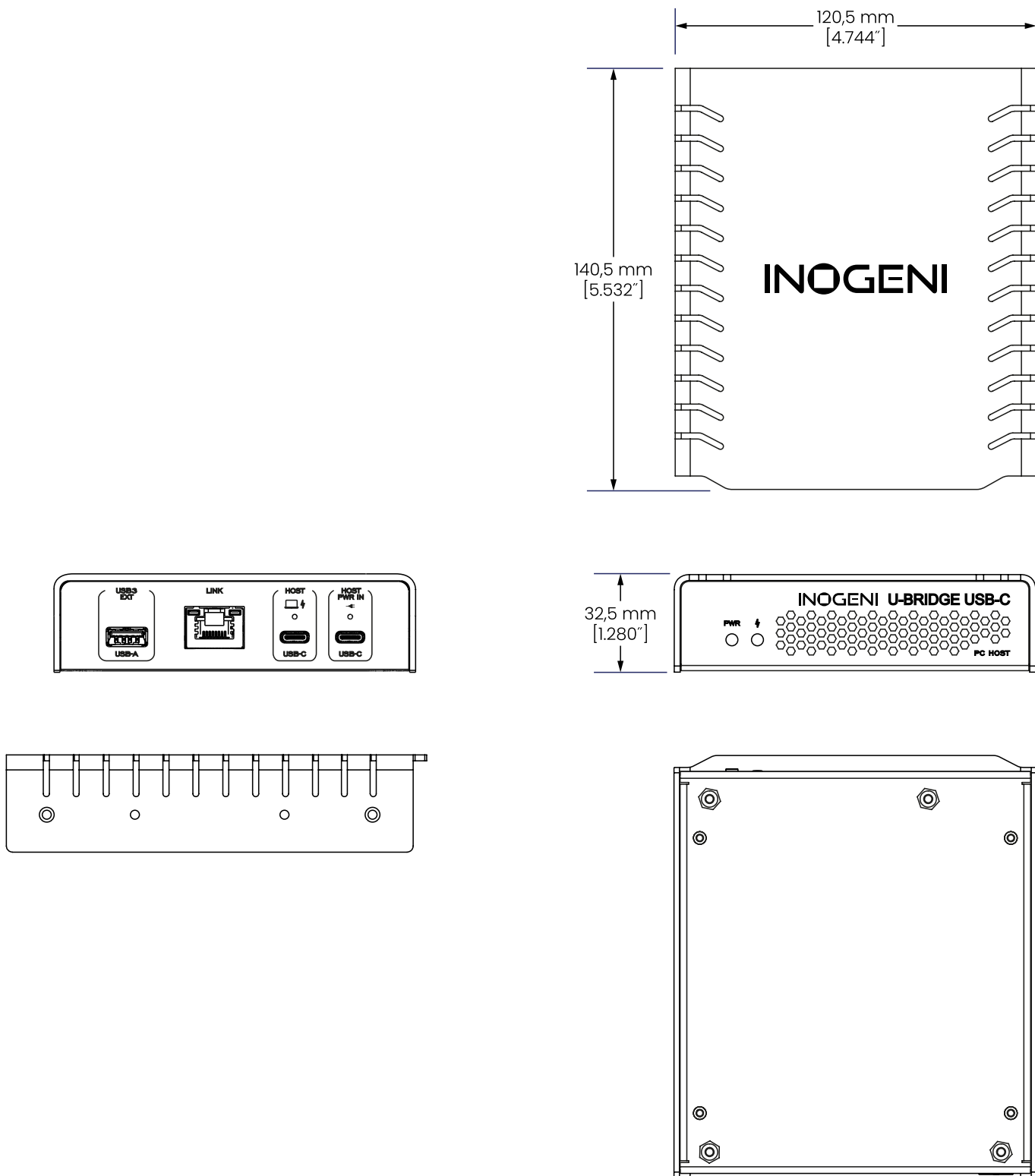

Figure 1: Bottom plate dimensions and holes positions of PC HOST hub – SINGLE variant

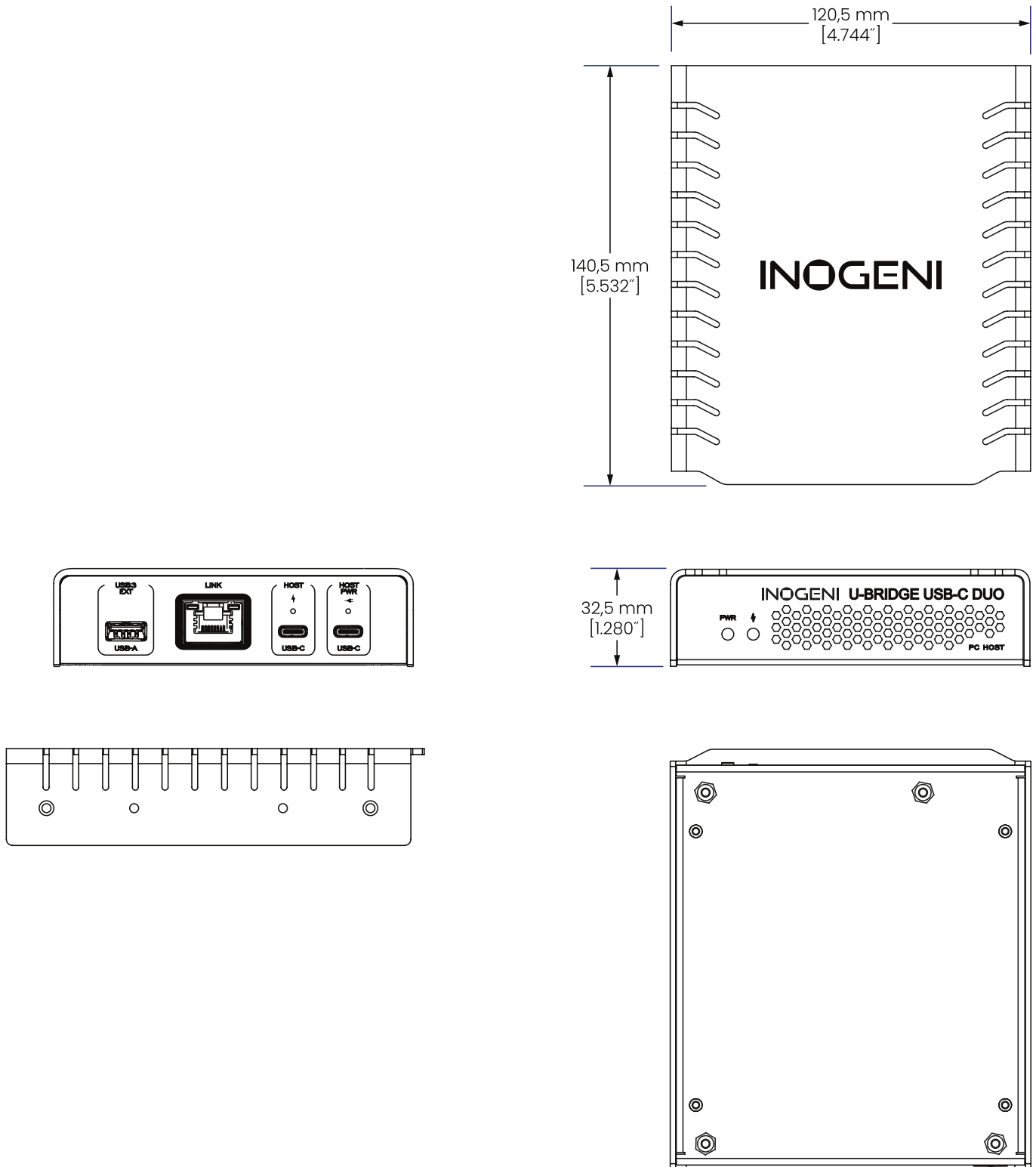

Figure 2: Bottom plate dimensions and holes positions of PC HOST hub – DUO variant

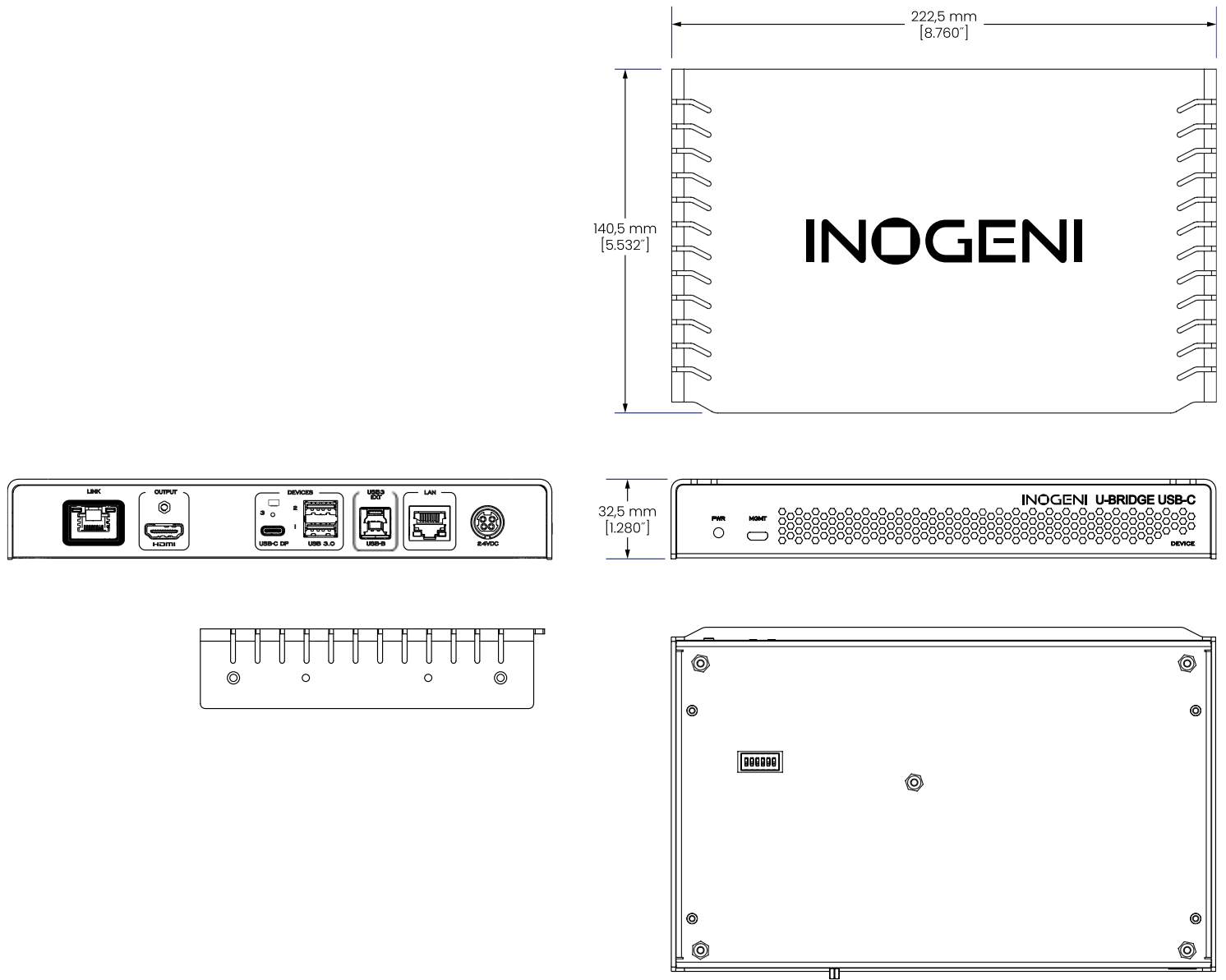

Figure 3: Bottom plate dimensions and holes positions of DEVICE hub – SINGLE variant

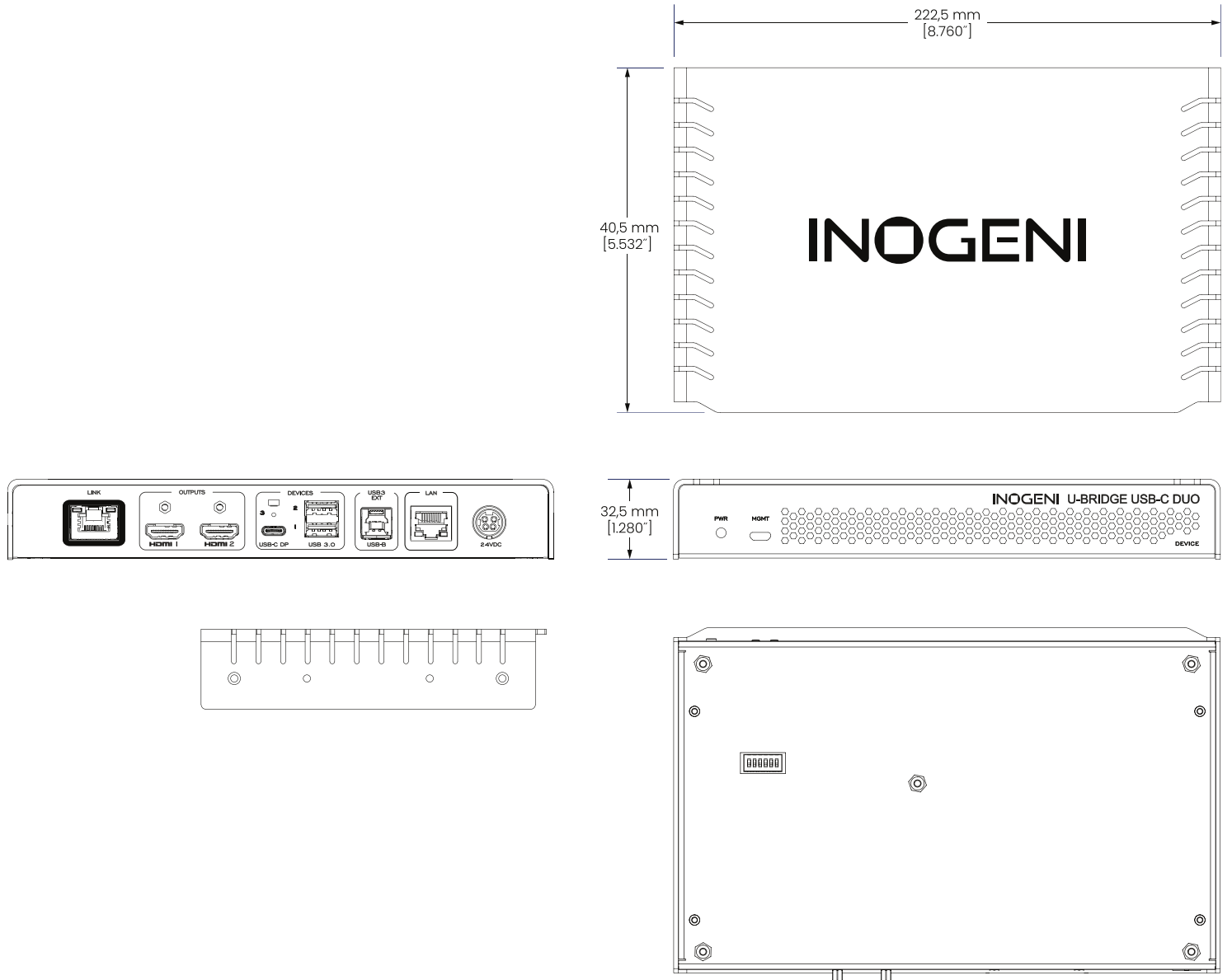

Figure 4: Bottom plate dimensions and holes positions of DEVICE hub – DUO variant

MOUNTING BRACKET

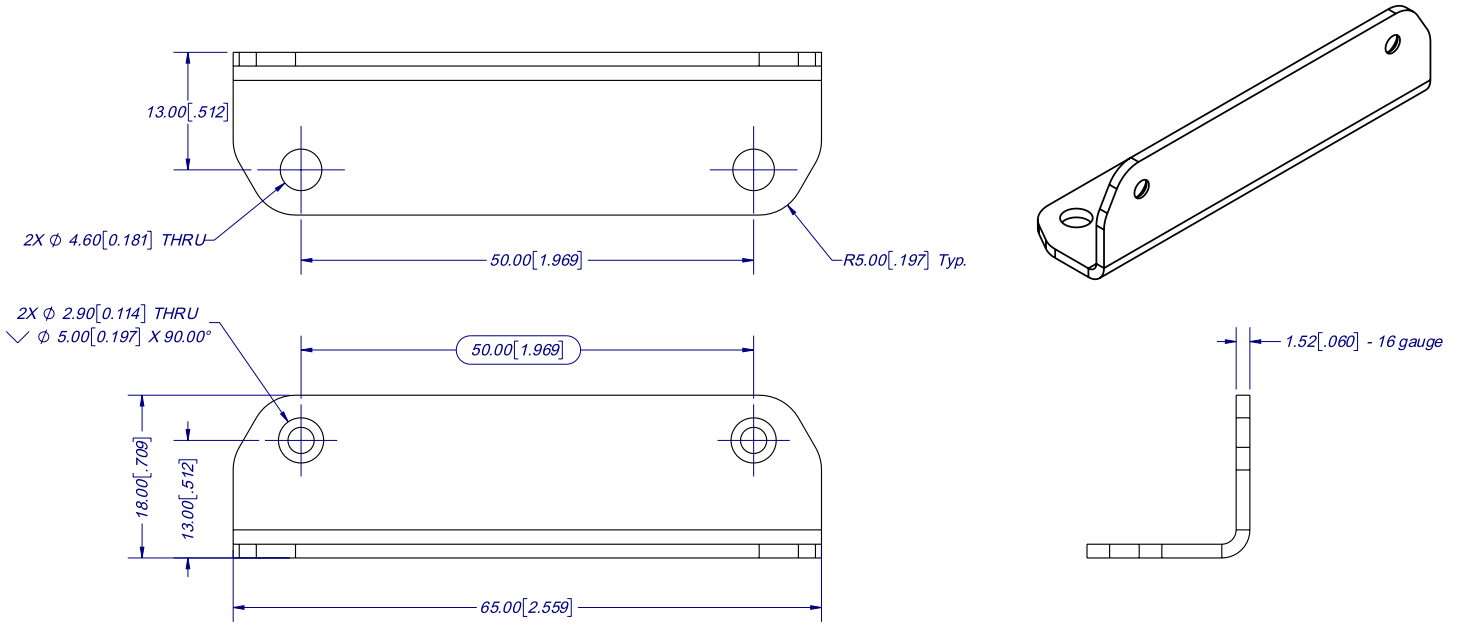

Figure 5: Bracket dimensions

60W POWER SUPPLY BRACKET

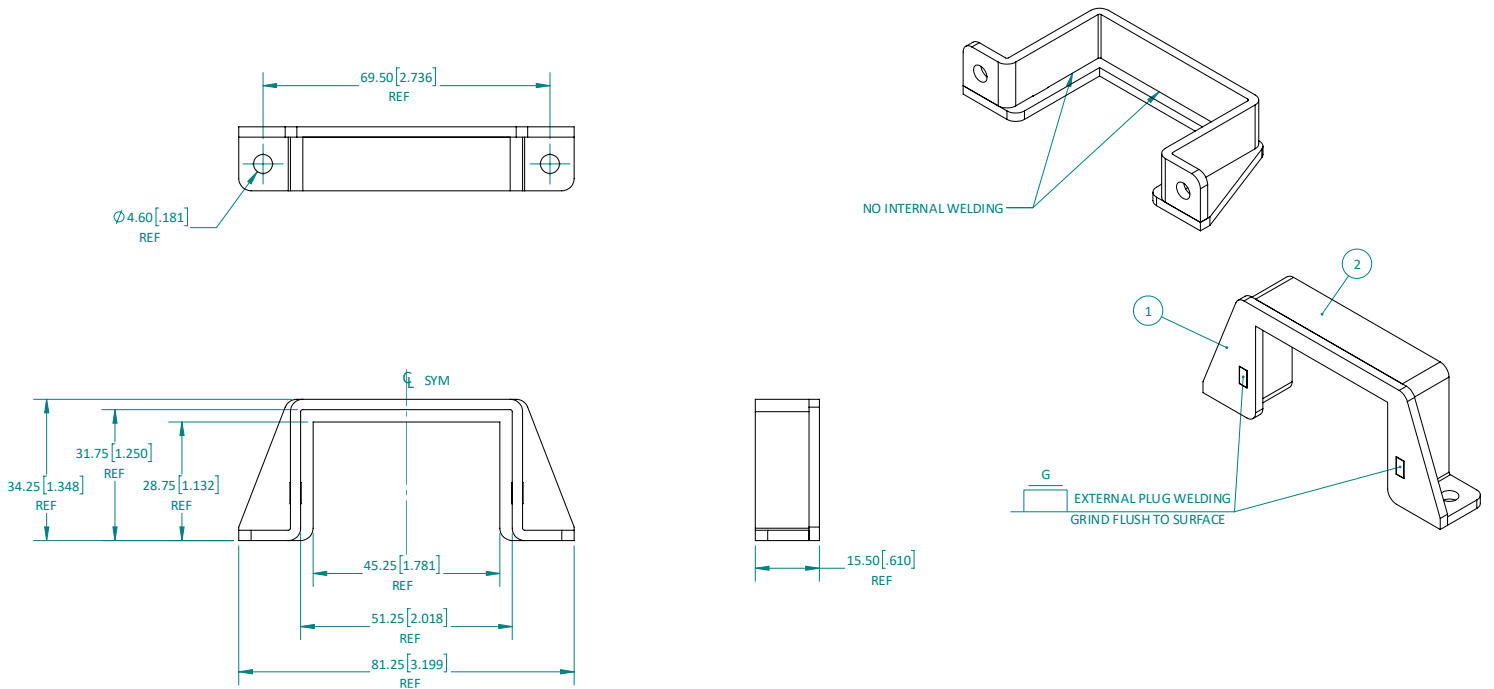

Figure 6: Power supply 60W bracket dimensions

100W USB-C POWER SUPPLY BRACKET

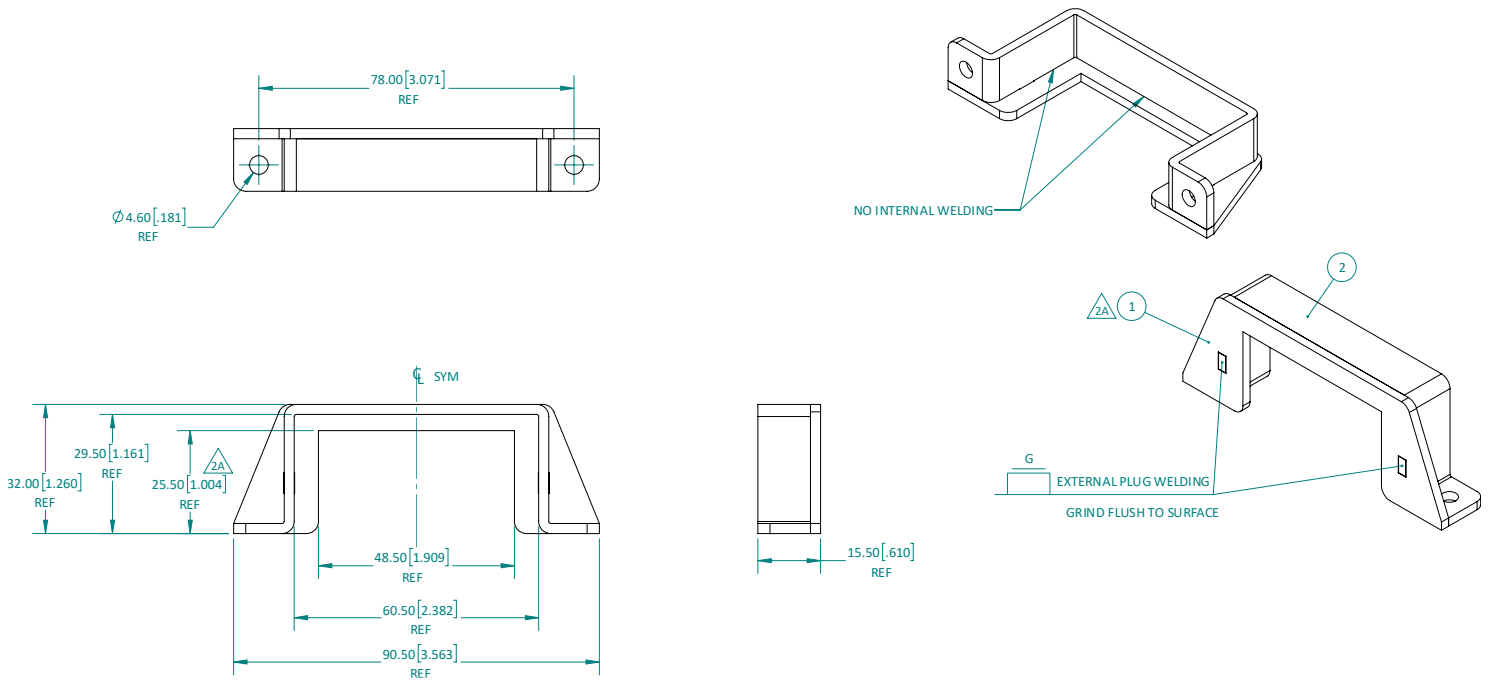

Figure 7: 100W USB-C power supply bracket dimensions

DIP SWITCHES

Here you can find the behavior of the DIP switches located below the DEVICE unit.

Switch	Position	Description
SW1	OFF	For future use.
	ON	
SW2	OFF	For future use.
	ON	
SW3	OFF	For future use.
	ON	
SW4	OFF	Reserved.
	ON	
SW5	OFF	Reserved.
	ON	
SW6	OFF	Enable USB to Ethernet bridge.
	ON	Disable USB to Ethernet bridge.

TROUBLESHOOTING SECTION

Here is the troubleshooting section for the device.

Problem	Resolution
My laptop is not charging using my USB-C cable.	Check if the cable is rated to support USB-C power delivery. Also check if the cable used is among the ones that we already support. Visit https://inogeni.com/product/u-bridge-usbc/ for the complete list. Make also sure that your BIOS and your system chipset drivers are up to date.
Using a U-BRIDGE USB-C DUO, I cannot have two 4K60 video feeds on my displays at the same time.	The U-BRIDGE USB-C DUO only support up to 3840x2160p 30 when two displays are connected at the same time. This is an HDBaseT limitation. If a single display is connected, you can send 3840x2160p 60 without issue.
Maestro does not see my device.	You need to use a USB-micro to USB-A cable between the DEVICE module and your PC for Maestro to detect the kit. Alternatively, you can connect the kit to your network and follow the procedure in the “web interface access” section.
I have no network connection on my Apple device.	There is a limitation of the embedded USB to Ethernet bridge. This one only works over Windows and Linux. macOS system will be supported in an upgraded hardware version.

Engineered by video professionals, for video professionals, it is your most compatible USB 3.0 device. INOGENI expertise at your fingertips:

- **Expert Technical Support team** at support@inogeni.com for immediate help or if you have any technical question about our products.
- Extensive **Knowledge Base** to learn from other customers' experiences.

© Copyright 2026 by INOGENI INC. All Rights Reserved.

INOGENI name and logo are trademarks or registered trademarks of INOGENI. Use of this product is subject to the terms and conditions of the license and limited warranty in effect at the time of purchase. Product specifications can change without notice.

INOGENI, Inc.
1045 Avenue Wilfrid-Pelletier
Suite 101
Québec, QC, Canada, G1W0C6
(418) 651-3383

CERTIFICATIONS



FCC Radio Frequency Interference Statement Warning

This device complies with Part 15 of the FCC rules. Operation is subject to the following two conditions:
(1) this device may not cause harmful interference, and
(2) this device must accept any interference received including interference that may cause undesired operation.

IC Statement

This Class A digital apparatus complies with Canadian CAN ICES-3(A)/NMB-3(A).



CE Statement

We, INOGENI Inc., declare under our sole responsibility that Toggle Rooms, to which this declaration relates, is in conformity with European Standards EN 55032, EN 55035, and RoHS Directive 2011/65/EU + 2015/863/EU.



UKCA Statement

This device is compliant with the Electromagnetic Compatibility Regulations 2016 No. 1091 as part of the requirements leading to the UKCA marking.



WEEE Statement

The European Union has established regulations for the collection and recycling of all waste electrical and electronic equipment (WEEE). Implementation of WEEE regulations may vary slightly by individual EU member states. Please check with your local and state government guidelines for safe disposal and recycling or contact your national WEEE recycling agency for more information.



RCM Statement

This device is compliant with Regulator Compliance Mark (RCM) certification.



NOM Statement

This device is compliant with the NOM-019 standard.



Product specifications can change without notice, we suggest to use the latest user guide version on [product website](#).